

Product Description

Designed for use in oven monitoring or other applications where a simple mounting bolt/screw is needed. The flanged design allows rapid assembly and low profile when going through bulkheads.

Application

- Plastic and Rubber Machines
- Packaging Machinery
- Machine building, plant and vessel construction
- Energy and power plant technology
- Chemical and petrochemical industry
- Food and beverage industry
- Heating and air-conditioning technology



Sensor Specification

- Number of Sensing Elements: 1
- Type of Thermocouple Sensing Junction: Ungrounded
- Thermocouple Tolerance: Class 1 - EN 60584
Class Special - ASTM E230
- Thermocouples are also available according to color coding DIN 43714 (withdrawn)
- RTD Tolerance: Class B - EN 60751

Technical Features

- Mounting Hole: $\varnothing 4$ mm
- Outside Sheath Length: 10 mm
- Probe Diameter: $\varnothing 4$ mm
- Probe Diameter Tolerance: $-0,15 / +0,05$ mm
- Probe Length Tolerance: $\pm 1,00$ mm
- “Center to Center” Hole Distance Tolerance: $\pm 0,20$ mm
- Sheath Material: AISI 304L (1.4307)
- Flange Thickness: 0,50 mm
- Flange Material: AISI 304L (1.4307)
- Terminals: stripped leads or split leads
- Max Operating Temperature: depending on the selected cable type
- Polyolefin Heat-Shrink Sleeve: used only with “BRA” type cable
- Product Identification: Product part number and work order number are laser printed on sensor sheath

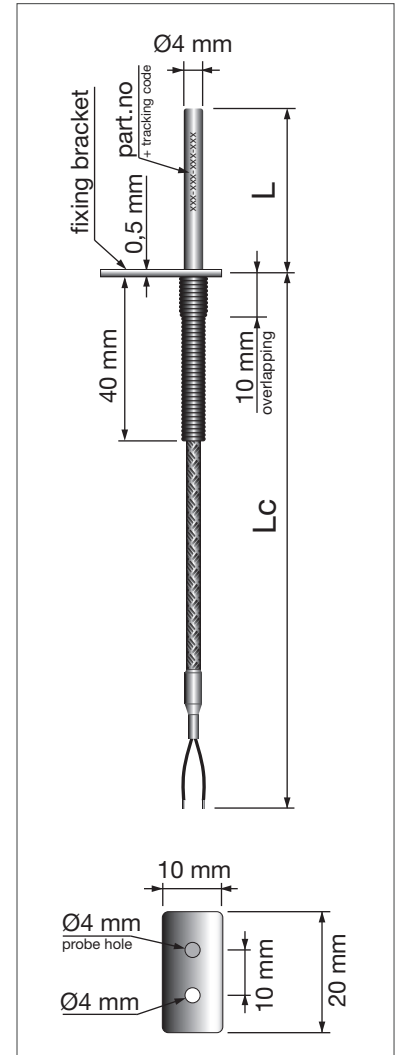

Product Configurator

5SB

TYPE OF SENSOR	
J	TC J (Fe-Co)
K	TC K (Cr-Al)
D	RTD - PT100 (2 wires)
F	RTD - PT100 (3 wires)
G	RTD - PT1000 (2 wires)
H	RTD - PT1000 (3 wires)

WIRE COLOUR CODE	
A	ASTM E230 (TC)
D	DIN 43714 (TC)
E	EN 60584 (TC)
R	EN 60751 (RTD)

INSERTION LENGTH (L)	
1	10 mm
2	20 mm

TYPE OF CABLE	
1	SIL (max 200°C)
2	MFA (max 220°C)
3	BRA (RTD max 220°C / TC max 400°C)

ORDER QUANTITY	
S	10 pcs
T	20 pcs
U	50 pcs
V	75 pcs
W	100 pcs
X	150 pcs
Y	200 pcs

TERMINALS	
S	Stripped Leads
P	Split Leads

CABLE LENGHT (Lc)	
A	500 mm
B	1000 mm
C	1500 mm
D	2000 mm
E	3000 mm



Temperature sensor cables

The cables for temperature sensors are the heart of instruments that measure temperature because they are the ones that form the circuit that determines the difference in potential (thermocouple) or transmit the electrical signal (RTD), which then in both cases the measuring instruments convert into the temperature reading. The cables offered by Zoppas meet the requirements of DIN, IEC and ASTM standards. Although the temperature sensor is designed to run at very high temperature, sensor lead wires and terminations are rated for much lower temperatures. Care should be taken to make sure that the sensor lead end temperatures do not exceed their limitations.

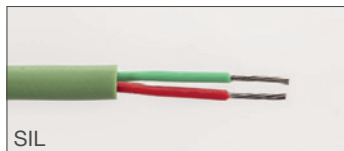

Cable Code	SIL
Description	Twisted MFA or Silicone insulated conductors covered with external silicone sheath
Features	Silicone rubber is a common choice for cable temperature sensors. Silicone rubber cables have excellent flexibility at both low temperatures and high temperatures. Furthermore, silicone rubber cables have accomplished electrical insulation properties.
Wire type	Solid or Stranded
Outside Shape	Rounded
External Jacket	Silicone Rubber (White for RTD sensors)
Conductor Insulation	MFA - Probe diameter ≤ 4 mm
Conductor Insulation	Silicone - Probe diameter > 4 mm
Temperature range	-40°C / +200°C
Type of conductors	J or K (Thermocouple) - Tinned Cu (RTD)

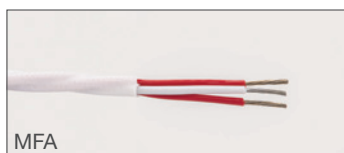

Cable Code	MFA
Description	Twisted MFA insulated conductors covered with external MFA sheath
Features	MFA cables are heat resistant, chemically inert, and have great dielectric properties. Resistant to oils, acids other adverse agents and fluids.
Wire type	Solid or Stranded
Outside Shape	Rounded
External Jacket	MFA (White for RTD sensors)
Conductor Insulation	MFA
Temperature range	-40°C / +220°C
Type of conductors	J or K (Thermocouple) - Tinned Cu (RTD)



Cable Code	BRA
Description	Twisted fiberglass insulated conductors, fiberglass filling and external tinned copper armouring
Features	The tinned copper braided cable provides abrasion resistance, easy installation into cable trays or ducts and resistance to high temperature (up to 400°C). Will not prevent ingress of fluids.
Wire type	Solid or Stranded
Outside Shape	Rounded
External Jacket	Tinned Copper
Conductor Insulation	Fiberglass
Temperature range	Thermocouple: 0°C / 400°C - RTD: 0°C / 220°C
Type of conductors	J or K (Thermocouple) - Tinned Cu (RTD)



Cable Code	SNG
Description	Twisted cables made of solid or stranded insulated conductors
Features	PFA is similar to MFA, but has a slightly different chemical composition, allowing it to withstand even higher temperatures than MFA. Good mechanical strength and flexibility.
Wire type	Solid (TC) or Stranded (RTD)
Outside Shape	Rounded
Conductor Insulation	PFA
Temperature range	TC -65°C / +260°C - RTD -65°C / +200°C
Type of conductors	J or K (Thermocouple) - Cu (RTD)

Standard color coding

Color coding of the thermocouple cables according to DIN, IEC and ASTM standards.

Color coding of RTD cables is also represented here below.

Standard colors	DIN 43714	IEC 584-3	ASTM E230	RTD TYPE
Thermo couple type				
J				
K				

Terminals

Our temperature sensors are available with two types of terminals: stripped leads or split leads terminals are made of tin plated electrolytic copper. Working Temperature Range: -20 / +115°C. Flexible temperature sensors available only with Stripped Leads.

